

JCB-MS-210SB

Original Instructions



GENERAL WARNINGS & DISPOSAL



To reduce the risk of injury, user must read the instruction manual



This symbol is used throughout this manual to warn the user about potential risks. Please read & understand these sections before using the device.



Personal Protective Equipment (P.P.E.) must be worn during the operation of the device.



The device must not be exposed to rain or immersed in water.



Do not allow any part of the device to come into contact with flame, or to catch fire.



Warning! Risk of injury! Do not touch the moving saw blade!



Protection rating II (double insulated)



This mitre saw is equipped with a class 2 laser.
Do not look into the laser beam

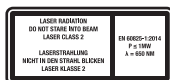

The month and year of manufacture can be found within the product serial number e.g. MMYPPPA XXXXX. Where production month (MM) and production year (YY) are included.



Contents

GENERAL SAFETY INSTRUCTIONS	5
Save all warnings and instructions for future reference	5
SAFETY INSTRUCTIONS FOR MITRE SAWS	7
Safety instructions for the handling of saw blades	9
COMPONENT LIST	12
TECHNICAL DATA	14
VIBRATION AND NOISE INFORMATION	15
OPERATING INSTRUCTIONS	16
Intended Use	16
Before starting the equipment	17
Attachment and operation	18
Attaching the saw	18
Precision adjustment of the stop for crosscut 90°	19
Cross cut 90° and turntable 0°	19
Cross cut 90° and turntable 0° - 45°	21
Precision adjustment of the stop for mitre cut 45°	21
Mitre cut 0° - 45° and turntable 0°	22
Mitre cut 0° - 45° and turntable 0° - 45°	23
Limiting the cutting depth	23
Sawdust bag	24
Changing the saw blade	24
MAINTENANCE AND WORKING INSTRUCTIONS	25
Maintenance	25
Electrical connection	25
Transport	26
Storage	26
DISPOSAL AND RECYCLING	27
WARRANTY STATEMENT	28
Conditions	28
Terms	29
EC DECLARATION OF CONFORMITY	31



GENERAL SAFETY INSTRUCTIONS

WARNING!

Read all safety warnings instructions, illustrations and specifications provided with this power tool.

Failure to follow the warnings and instructions may result in electric shock, fire and/or serious injury. The term "power tool" in the warnings refers to your mains-operated (corded) power tool or battery-operated (cordless) power tool.

Save all warnings and instructions for future reference.

1 Work area safety

- a **Keep work area clean and well lit**
 - Cluttered and dark areas invite accidents.
- b **Do not operate power tools in explosive atmospheres, such as in the presence of flammable liquids, gases or dust.**
 - Power tools create sparks which may ignite the dust or fumes.
- c **Keep children and bystanders away while operating a power tool.**
 - Distractions can cause you to lose control.

2 Electrical safety

- a **Power tool plugs must match the outlet. Never modify the plug in any way. Do not use any adapter plugs with earthed (grounded) power tools**
 - Unmodified plugs and matching outlets will reduce risk of electric shock.

- b **Avoid body contact with earthed or grounded surfaces such as pipes, radiators, ranges and refrigerators.**
 - There is an increased risk of electric shock if your body is earthed or grounded.
- c **Do not expose power tools to rain or wet conditions.**
 - Water entering a power tool will increase the risk of electric shock.
- d **Do not abuse the cord. Never use the cord for carrying, pulling or unplugging the power tool. Keep cord away from heat, oil, sharp edges or moving parts.**
 - Damaged or entangled cords increase the risk of electric shock.
- e **When operating a power tool outdoors, use an extension cord suitable for outdoor use.**
 - Use of a cord suitable for outdoor use reduces the risk of electric shock.
- f **If operating a power tool in a damp location is unavoidable, use a residual current device(RCD) protected supply**
 - Use of an RCD reduces the risk of electric shock.

3 Personal safety

- a **Stay alert, watch what you are doing and use common sense when operating a power tool. Do not use a power tool while you are tired or under the influence of drugs, alcohol or medication.**
 - A moment of inattention while operating power tools may result in serious personal injury.
- b **Use safety equipment. Always wear eye protection.**
 - Safety equipment such as dust mask, non-skid safety shoes, hard hat, or



- hearing protection used for appropriate conditions will reduce personal injuries.
 - c Prevent unintentional starting. Ensure the switch is in the off-position before connecting to power source and/or battery pack, picking up or carrying the tool.**
 - Carrying power tools with your finger on the switch or energizing power tools that have the switch on invites accidents.
 - d Remove any adjusting key or wrench before turning the power tool on.**
 - A wrench or a key left attached to a rotating part of the power tool may result in personal injury.
 - e Do not overreach. Keep proper footing and balance at all times.**
 - This enables better control of the power tool in unexpected situations.
 - f Dress properly. Do not wear loose clothing or jewellery. Keep your hair, clothing and gloves away from moving parts.**
 - Loose clothes, jewellery or long hair can be caught in moving parts.
 - g If devices are provided for the connection of dust extraction and collection facilities, ensure these are connected and properly used.**
 - Use of these devices can reduce dust related hazards.
 - h Do not let familiarity gained from frequent use of tools allow you to become complacent and ignore tool safety principles.**
 - A careless action can cause severe injury within a fraction of a second.
- 4 Power tool use and care**
- a Do not force the power tool. Use the correct power tool for your application.**
 - The correct power tool will do the job better and safer at the rate for which it was designed.
 - b Do not use the power tool if the switch does not turn it on and off.**
 - Any power tool that cannot be controlled with the switch is dangerous and must be repaired.
 - c Disconnect the plug from the power source before making any adjustments, changing accessories, or storing power tools.**
 - Such preventive safety measures reduce the risk of starting the power tool accidentally.
 - d Store idle power tools out of the reach of children and do not allow persons unfamiliar with the power tool or these instructions to operate the power tool.**
 - Power tools are dangerous in the hands of untrained users.
 - e Maintain power tools. Check for misalignment or binding of moving parts, breakage of parts and any other condition that may affect the power tools operation. If damaged, have the power tool repaired before use.**
 - Many accidents are caused by poorly maintained power tools.
 - f Keep cutting tools sharp and clean.**
 - Properly maintained cutting tools with sharp cutting edges are less likely to bind and are easier to control.
 - g Use the power tool, accessories and tool bits etc., in accordance with**

these instructions and in the manner intended for the particular type of power tool, taking into account the working conditions and the work to be performed.

- Use of the power tool for operations different from intended could result in a hazardous situation.
- h **Keep handles and grasping surfaces dry, clean and free from oil and grease.**
 - Slippery handles and grasping surfaces do not allow for safe handling and control of the tool in unexpected situations.
- 5 **Service**
 - a **Have your power tool serviced by a qualified repair person using only identical replacement parts.**
 - This will ensure that the safety of the power tool is maintained.

SAFETY INSTRUCTIONS FOR MITRE SAWS

- 1 **Mitre saws are intended to cut wood or wood-like products, they cannot be used with abrasive cut-off wheels for cutting ferrous material such as bars, rods, studs, etc.**
 - Abrasive dust causes moving parts such as the lower guard to jam. Sparks from abrasive cutting will burn the lower guard, the kerf insert and other plastic parts.
- 2 **Use clamps to support the workpiece whenever possible. If supporting the workpiece by hand, you must always keep your hand at least 100 mm from either side of the saw blade. Do not use this saw to cut pieces that are too small to be securely clamped or held by hand.**
 - If your hand is placed too close to the saw blade, there is an increased risk of injury
- 3 **The workpiece must be stationary and clamped or held against both the fence and the table. Do not feed the workpiece into the blade or cut “freehand” in any way.**
 - Unrestrained or moving workpieces could be thrown at high speeds, causing injury.
- 4 **Push the saw through the workpiece. Do not pull the saw through the workpiece. To make a cut, raise the saw head and pull it out over the workpiece without cutting, start the motor, press the saw head down and push the saw through the workpiece.**
 - Cutting on the pull stroke is likely to cause the saw blade to climb on top of the workpiece and violently throw the blade assembly towards the operator.
- 5 **Never cross your hand over the intended line of cutting either in front or behind the saw blade.**
 - Supporting the workpiece “cross handed” i.e. holding the workpiece to the right of the saw blade with your left hand or vice versa is very dangerous.
- 6 **Do not reach behind the fence with either hand closer than 100 mm from either side of the saw blade, to remove wood scraps, or for any other reason while the blade is spinning.**
 - The proximity of the spinning saw blade to your hand may not be obvious and you may be seriously injured.
- 7 **Inspect your workpiece before cutting. If the workpiece is bowed or warped, clamp it with the outside bowed face toward the fence. Always make certain that there is no gap between the workpiece, fence and table along the line of the cut**
 - Bent or warped workpieces can twist or shift and may cause binding on the spinning saw blade while cutting. There



should be no nails or foreign objects in the workpiece.

- 8 **Do not use the saw until the table is clear of all tools, wood scraps, etc., except for the workpiece.**
 - Small debris or loose pieces of wood or other objects that contact the revolving blade can be thrown with high speed.
- 9 **Cut only one workpiece at a time.**
 - Stacked multiple workpieces cannot be adequately clamped or braced and may bind on the blade or shift during cutting.
- 10 **Ensure the mitre saw is mounted or placed on a level, firm work surface before use.**
 - A level and firm work surface reduces the risk of the mitre saw becoming unstable.
- 11 **Plan your work. Every time you change the bevel or mitre angle setting, make sure the adjustable fence is set correctly to support the workpiece and will not interfere with the blade or the guarding system.**
 - Without turning the tool “ON” and with no workpiece on the table, move the saw blade through a complete simulated cut to assure there will be no interference or danger of cutting the fence.
- 12 **Provide adequate support such as table extensions, saw horses, etc. for a workpiece that is wider or longer than the table top.**
 - Workpieces longer or wider than the mitre saw table can tip if not securely supported. If the cut-off piece or workpiece tips, it can lift the lower guard or be thrown by the spinning blade.
- 13 **Do not use another person as a substitute for a table extension or as additional support.**
 - Unstable support for the workpiece can cause the blade to bind or the workpiece to shift during the cutting operation pulling you and the helper into the spinning blade.
- 14 **The cut-off piece must not be jammed or pressed by any means against the spinning saw blade.**
 - If confined, i.e. using length stops, the cut-off piece could get wedged against the blade and thrown violently.
- 15 **Always use a clamp or a fixture designed to properly support round material such as rods or tubing.**
 - Rods have a tendency to roll while being cut, causing the blade to “bite” and pull the work with your hand into the blade.
- 16 **Let the blade reach full speed before contacting the workpiece.**
 - This will reduce the risk of the workpiece being thrown.
- 17 **If the workpiece or blade becomes jammed, turn the mitre saw off. Wait for all moving parts to stop and disconnect the plug from the power source and/or remove the battery pack. Then work to free the jammed material.**
 - Continued sawing with a jammed workpiece could cause loss of control or damage to the mitre saw.
- 18 **After finishing the cut, release the switch, hold the saw head down and wait for the blade to stop before**

removing the cut-off piece.

- Reaching with your hand near the coasting blade is dangerous.

19 Hold the handle firmly when making an incomplete cut or when releasing the switch before the saw head is completely in the down position.

- The braking action of the saw may cause the saw head to be suddenly pulled downward, causing a risk of injury.

WARNING!

This electric tool generates an electromagnetic field during operation. This field can impair active or passive medical implants under certain conditions. In order to prevent the risk of serious or deadly injuries, we recommend that persons with medical implants consult with their physician and the manufacturer of the medical implant prior to operating the electric tool.

Safety instructions for the handling of saw blades

- 1 Only use insertion tools if you have mastered their use.
- 2 Observe the maximum speed. The maximum speed specified on the insertion tool may not be exceeded. If specified, observe the speed range.
- 3 Observe the motor / saw blade direction of rotation.
- 4 Do not use any insertion tools with cracks. Sort out cracked insertion tools. Repairs are not permitted.
- 5 Clean grease, oil and water off of the clamping surfaces.
- 6 Do not use any loose reducing rings or bushes for the reducing of holes on saw blades.
- 7 Make sure that fixed reducer rings for securing the insertion tool have the same diameter and have at least 1/3 of the cutting diameter.
- 8 Make sure that fixed reducer rings are parallel to each other.
- 9 Handle insertion tool with caution. They are ideally stored in the originally package or special containers. Wear protective gloves in order to improve grip and to further reduce the risk of injury.
- 10 Prior to the use of insertion tools, make sure that all protective devices are properly fastened.
- 11 Prior to use, make sure that the insertion tool meets the technical requirements of this electric tool and is properly fastened.
- 12 Only use the supplied saw blade for cutting wood, never for the processing of metals.





Attention: Laser radiation
Do not stare into the beam
Class 2 laser



**Protect yourself and your environment
from accidents using suitable precau-
tionary measures!**

- Do not look directly into the laser beam with unprotected eyes.
- Never look into the path of the beam.
- Never point the laser beam towards reflecting surfaces and persons or animals. Even a laser beam with a low output can cause damage to the eyes.
- Caution - methods other than those specified here can result in dangerous radiation exposure.
- Never open the laser module. Unexpected exposure to the beam can occur.
- If the mitre saw is not used for an extended period of time, the batteries should be removed.
- The laser may not be replaced with a different type of laser.
- Repairs of the laser may only be carried out by the laser manufacturer or an authorised representative.



COMPONENT LIST

Fig.1

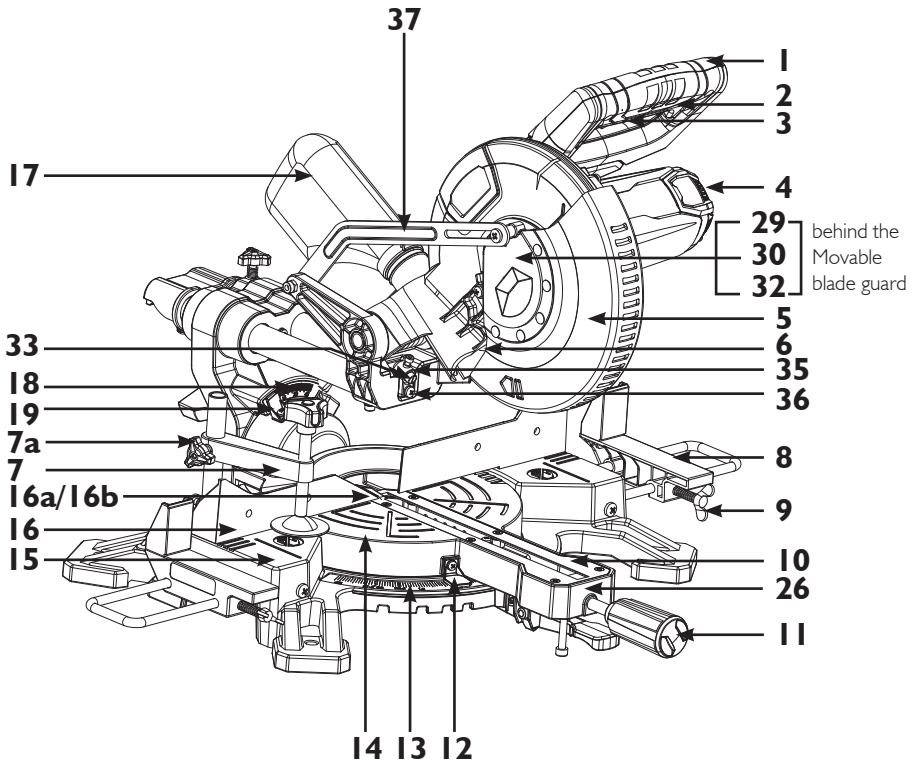

- | | | | |
|-----|-------------------------------------|-----|-----------------|
| 1. | Handle | 10. | Table insert |
| 2. | ON/OFF switch | 11. | Locking handle |
| 3. | Release button | 12. | Pointer |
| 4. | Machine head | 13. | Mitre scale |
| 5. | Movable blade guard | 14. | Turntable |
| 6. | Saw blade | 15. | Fixed saw table |
| 7. | Clamping device | 16. | Stop rail |
| 7a. | Grip screw | 16a | Extension block |
| 8. | Workpiece support | 16b | Set screw |
| 9. | Locking screw for workpiece support | 17. | Sawdust bag |



Fig.2

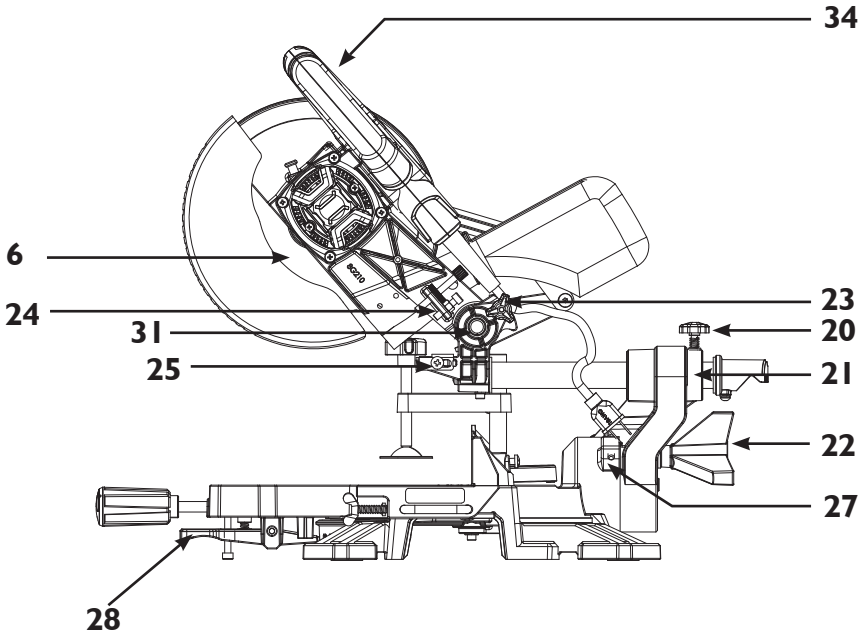

- | | |
|--|------------------------------------|
| 18. Scale | 28. Mitre detent |
| 19. Pointer | 29. Flange bolt |
| 20. Locking screw for drag guide | 30. Outer flange |
| 21. Drag guide | 31. Saw shaft lock |
| 22. Locking screw | 32. Inner flange |
| 23. Fastening bolt | 33. Laser |
| 24. Screw for cutting depth limiter | 34. ON/OFF switch for laser |
| 25. Stop for cutting depth limiter | 35. Laser compartment |
| 26. Fastening bolt for turn table | 36. Laser holder |
| 27. Adjustment screw (90°) | 37. Guide bar |

TECHNICAL DATA

AC motor	220 - 240 V~ 50 Hz
Power	1500 W
Idle speed n_0	4500 /min
Carbide saw blade	210 x 30 x 2.6mm
Number of teeth	24
Swivel range	-45° / 0° / +45°
Mitre cut	0° - 45° to the left
Saw width at 90°	220 x 70 mm
Saw width at 45°	155 x 70 mm
	220 x 35 mm
Saw width at 2 x 45° (double mitre cut)	155 x 35 mm
Protection class	II /
Weight net / gross	13 / 15.2 kg
Laser class	2
Wavelength of laser	650nm
Laser output	< 1mW

Technical changes reserved!

WARNING!

The work piece must have a minimum height of 3mm and a minimum width of 10 mm.

Make sure that the workpiece is always secured with the clamping device.



VIBRATION AND NOISE INFORMATION

Total noise values determined in accordance with EN 62841

A-Weighted Sound Pressure (L_{pA})	93,6 dB(A)
Uncertainty K_{pA}	3 dB
A-Weighted Sound Level (L_{wA})	106,6 dB(A)
Uncertainty K_{wA}	3 dB
Wear ear protection when sound pressure is over 80 dB(A)	

WARNING!

Wear hearing protection.

The effects of noise can cause a loss of hearing. The above-mentioned noise emission values were measured in accordance with a standardised test procedure and can be used to compare one power tool with another.

The above-mentioned noise emission values can also be used for the preliminary assessment of exposure.

Warning:

The noise emissions during the actual use of the power tool may differ from the above-mentioned values depending on the power tool being used, in particular on the type of workpiece being processed.

Try to keep emissions as low as possible, for example by limiting your working time. In this regard, all the operational cycle phases must be taken into consideration (such as the times when the tool is switched off or running idle).



OPERATING INSTRUCTIONS

Intended Use

The drag, crosscut and mitre saw is designed to crosscut wood and plastic respective of the machine's size. The saw is not designed for cutting firewood.

WARNING!

Do not use the saw to cut materials other than those specified described in manual.

WARNING!

The supplied saw blade is only intended for the sawing of wood! Do not use this blade for the sawing of plastic!

The equipment is to be used only for its prescribed purpose. Any other use is deemed to be a case of misuse. The user / operator and not the manufacturer will be liable for any damage or injuries of any kind caused as a result of this.

The equipment is to be operated only with suitable saw blades. It is prohibited to use any type of cutting-off wheel.

To use the equipment properly you must also observe the safety information, the assembly instructions and the operating instructions to be found in this manual.

All persons who use and service the equipment have to be acquainted with this manual and must be informed about the equipment's potential hazards. It is also imperative to observe the accident prevention regulations in force in your area. The same applies for the general rules of health and safety at work.

The manufacturer will not be liable for any changes made to the equipment nor for any damage resulting from such changes. Even when the equipment is used as prescribed it is still impossible to eliminate certain residual risk factors. The following hazards may arise in connection with the machine's construction and

design:

- Contact with the saw blade in the uncovered saw zone.
- Reaching into the running saw blade (cut injuries).
- Kick-back of workpieces and parts of workpieces.
- Saw blade fracturing.
- Catapulting of faulty carbide tips from the saw blade.
- Damage to hearing if ear-muffs are not used as necessary.
- Harmful emissions of wood dust when used in closed rooms.

Please observe that our equipment was not designed with the intention of use for commercial or industrial purposes. We assume no guarantee if the equipment is used in commercial or industrial applications, or for equivalent work.



Before starting the equipment

- The equipment must be set up where it can stand securely. Secure the machine on a workbench or a stand with 4 screws through the holes in the fixed saw table (15).
- All covers and safety devices have to be properly fitted before the equipment is switched on.
- It must be possible for the blade to run freely.
- When working with wood that has been processed before, watch out for foreign bodies such as nails or screws, etc.
- Before you press the ON/OFF switch check that the saw blade is fitted correctly. Moving parts must run smoothly.
- Before you connect the equipment to the power supply make sure the data on the rating plate are identical to the mains data.

Do not use the tool if the switch does not allow you to switch from the ON state to the OFF state.



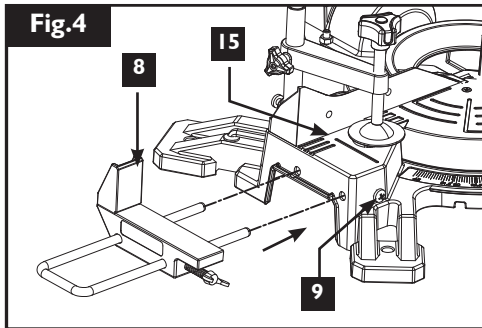
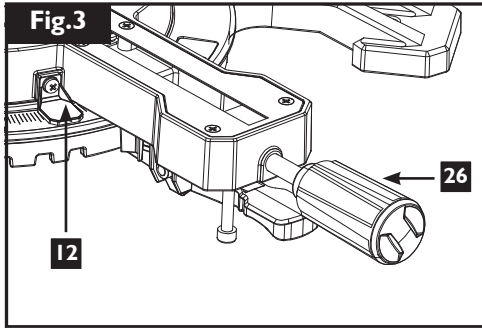

Attachment and operation

WARNING!

For your own safety, only insert the mains plug in an outlet when all assembly steps have been completed and you have read and understood the safety and operating instructions.

Lift the saw out of the packaging and place it on your work bench. (Positioning of the saw on the work bench - see the next page under „POSITIONING / WORK STATION“)

Attaching the saw (Fig1/2/3/4)

- In order to adjust the turntable (14) loosen the set screw (26) approx. 2 turns.
- Turn the turntable (14) and pointer (12) to the desired angle measurement on the scale (13) and secure with the set screw (26).
- Pressing the machine head (4) lightly downwards and removing the fastening bolt (23) from the motor bracket at the same time disengages the saw from the lowest position.
- Swing the machine head (4) up until the release button (3) latches into place.
- It is possible to secure the clamping device (7) to the left or right on the fixed saw table (15). Insert the clamping device (7) in the hole on the rear side of the stop rail (16) and secure it with the star grip screw (7a).
- Attach the workpiece supports (8) to the fixed saw table (15) as shown in Figure 4 and fasten with the screw (9).
- It is possible to tilt the machine head (4) a max. 45° to the left by loosening the locking screw (22).



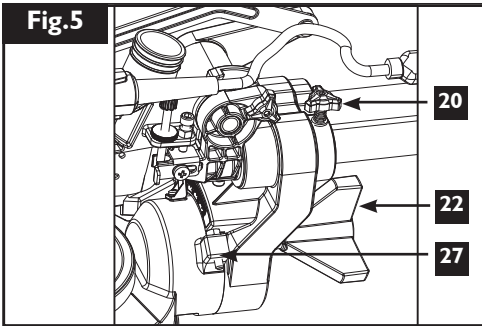

Precision adjustment of the stop for crosscut 90° (Fig. 1/5/6)

- No stop angle included.
- Lower the machine head (4) and secure using the fastening bolt (23).
- Loosen the locking screw (22).
- Position the angle stop between the saw blade (6) and the turntable (14).
- Adjust the adjusting screw (27) until the angle between the saw blade (6) and rotary table (14) is 90°.
- It is not necessary to fix this setting because it is maintained by the spring pretension. Subsequently check the position of the angle indicator. If necessary loosen the pointer (19) using a Philips screwdriver, set to position 0° on the bevel scale (18) and re-tighten the retaining screw

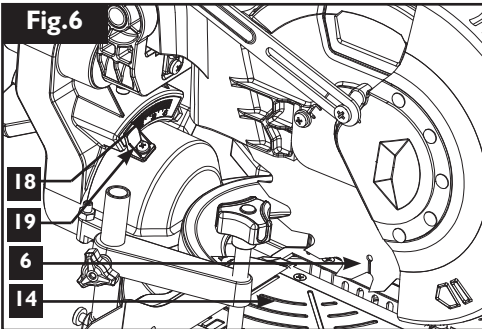

Cross cut 90° and turntable 0° (Fig.7)

In the case of cutting widths up to approx. 100 mm it is possible to fix the traction function of the saw with the locking screw (20) in the rear position. In this position the machine can be operated in cross cutting mode. If the cutting width is over 100 mm then it is necessary to ensure that the locking screw (20) is loose and the machine head (4) can move.

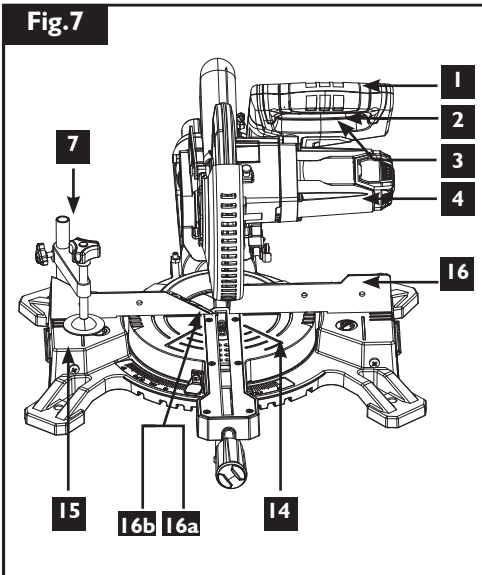

- Open the set screw (16b) on the moveable extension block (16a) and push the extension block (16a) inwards.
- The moveable extension block (16a) must be locked in a position far enough from the inner position that the distance between the extension block (16a) and the saw blade (6) is no more than 8 mm.
- Before making the cut, check that no collision could occur between the extension block (16a) and the saw blade (6).

- Tighten the set screw (16b) again.
- Move the machine head (4) to its upper position.
- Use the handle (1) to push back the machine head (4) and fix it in this position if required (dependent on the cutting width).
- Place the piece of wood to be cut at the stop rail (16) and on the turntable (14).
- Lock the material with the clamping device (7) on the fixed saw table (15) to prevent the material from moving during the cutting operation.
- Push down the release button (3) to release the machine head (4).
- Press the ON/OFF switch (2) to start the motor.
- With the drag guide (21) fixed in place:
 - use the handle (1) to move the machine head (4) steadily and with light pressure downwards until the saw blade (6) has completely cut through the work piece.
- With the drag guide (21) not fixed in place:
 - pull the machine head (4) all the way to the front. Lower the handle (1) to the very bottom by applying steady and light downward pressure. Now push the machine head (4) slowly and steadily to the very back until the saw blade (6) has completely cut through the work piece.
- When the cutting operation is completed, move the machine head (4) back to its upper (home) position and release the ON/OFF button (2).

Attention! The machine executes an upward stroke automatically due to the return spring, i.e. do not release the handle (1) after completing the cut; instead allow the machine head to move upwards slowly whilst applying light counter pressure



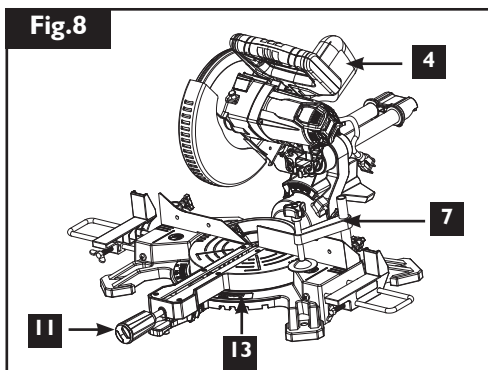

Cross cut 90° and turntable 0° - 45° (Fig. 8)

The crosscut saw can be used to make crosscuts of 0° -45° to the left and 0° -45° to the right in relation to the stop rail.

Important. To make 90° crosscuts, the adjustable extension block (16a) must be fixed at the inner position.

- Open the set screw (16b) for the adjustable stop rail and push the adjustable stop rail inwards.
- The extension block (16a) must be fixed far enough in front of the innermost position that the distance between the extension block (16a) and the saw blade (6) amounts to a maximum of 8 mm.
- Before making a cut, check that the extension block (16a) and the saw blade (6) cannot collide.
- Secure the set screw (16b) again.
- Loosen set screw (26).
- Use the handle (11) to adjust the turntable (14) to the desired angle. The pointer (12) on the rotary table must match the desired angle on the scale (13) on the fixed saw table (15).
- Re-tighten the set screw (26) in order to secure the turntable (14).
- Cut as described under section "Cross cut 90° and turntable 0°".

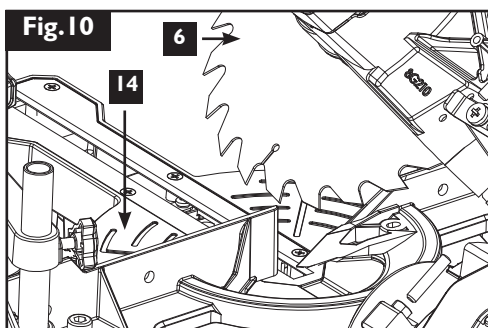
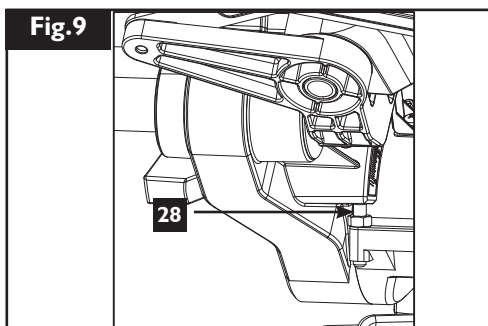

Precision adjustment of the stop for mitre cut 45° (Fig. 1/9/10)

- No stop angle included.
- Lower the machine head (4) and secure using the fastening bolt (23).
- Fix the turntable (14) in the 0° position.
- Loosen the locking screw (22) and use the handle (1) to angle the machine head (4) 45° to the left.
- 45° - position angle stop between the saw blade (6) and turntable (14).

Fig. 11

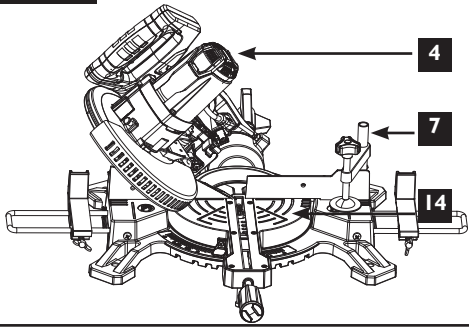

- Adjust the adjusting screw (28) until the angle between the saw blade (6) and rotary table (14) is precisely 45°.
- It is not necessary to fix this setting because it is maintained by the spring pretension.
- Subsequently check the position of the angle indicator. If necessary loosen the pointer (19) using a Philips screwdriver, set to position 45° on the angle scale (18) and re-tighten the retaining screw.

Mitre cut 0°- 45° and turntable 0° (Fig. 11)

The crosscut saw can be used to make mitre cuts of 0° - 45° in relation to the work face.

Important. To make miter cuts (inclined saw head), the extension block (16a) must be fixed at the outer position.

- Open the set screw (16b) for the extension block (16a) and push the adjustable stop rail outwards.
- The extension block (16a) must be fixed far enough in front of the innermost position that the distance between the extension block (16a) and the saw blade (6) amounts to a maximum of 8 mm.
- Before making a cut, check that the extension block(16a) and the saw blade (6) cannot collide.
- Secure the set screw (16b) again.
- Move the machine head (4) to the top position.
- Fix the turntable (14) in the 0° position.
- Loosen the locking screw (22) and use the handle (1) to angle the machine head (4) to the left, until the pointer (19) indicates the desired angle measurement on the scale (18).
- Re-tighten the locking screw (22).
- Cut as described in section “Cross cut 90° and turntable 0°”.

Fig.12

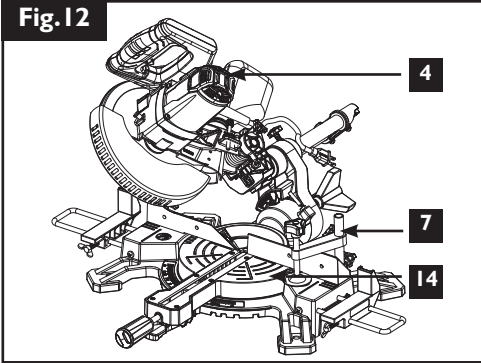

Mitre cut 0°- 45° and turntable 0°- 45° (Fig. 1/2/12)

The crosscut saw can be used to make mitre cuts to the left of 0° - 45° in relation to the work face and, at the same time, 0° - 45° to the left or 0° - 45° to the right in relation to the stop rail (double mitre cut).

Important. To make miter cuts (inclined saw head), the extension block (16a) must be fixed at the outer position.

Fig.13

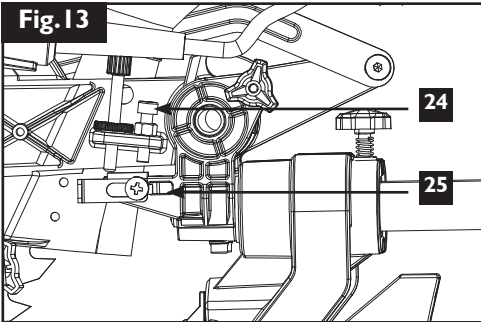

- Open the set screw (16b) for the extension block (16a) and push the extension block (16a) outwards.
- The extension block (16a) must be fixed far enough in front of the innermost position that the distance between the extension block (16a) and the saw blade (5) amounts to a maximum of 8 mm.
- Before making a cut, check that the extension block (16a) and the saw blade (5) cannot collide.
- Secure the set screw (16b) again.
- Move the machine head to its upper position
- Release the workpiece support (8) by loosening the set screw (21).
- Using the handle (2), set the workpiece support (8) to the desired angle (refer also to point "Cross cut 90° and turntable 0° - 45°" in this regard).
- Undo the fastening bolt (23)

Limiting the cutting depth (Fig. 2/13)

- The cutting depth can be infinitely adjusted using the screw (24). To do this loosen the knurled nut on the screw (24). Move the stop for the cutting depth limiter (25) to the outside. Turn the screw (24) in or out to set the required cutting depth. Then re-tighten the knurled nut on the screw (24).
- Check the setting by completing a test cut.

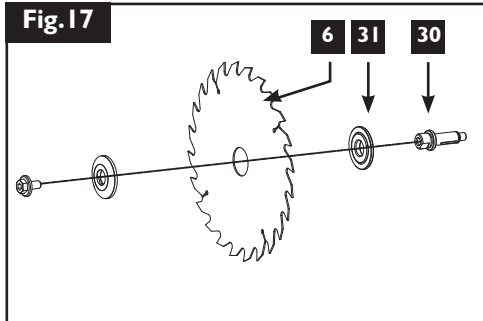
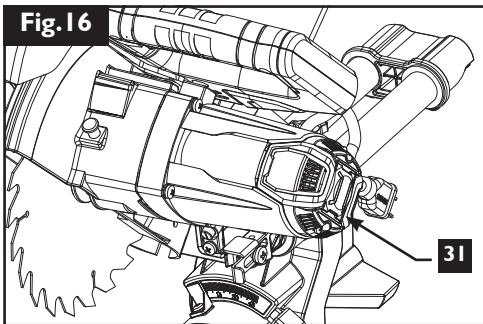
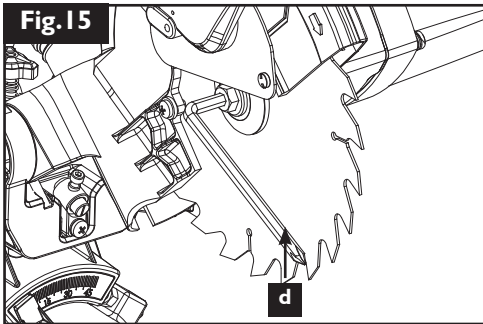
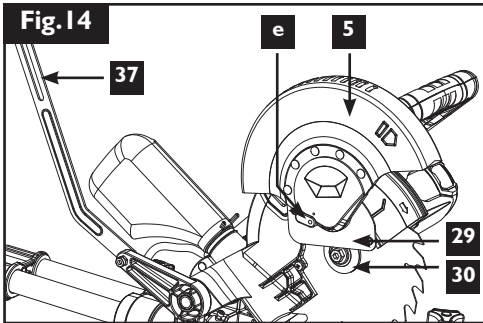

Sawdust bag (Fig. 1)

The saw is equipped with a sawdust bag (17) for sawdust and chips.

Squeeze together the metal ring on the dust bag and attach it to the outlet opening in the motor area.

The sawdust bag (17) can be emptied by means of a zipper at the bottom.

Changing the saw blade (Fig. 14/15/16/17)

Remove the power plug!

Important.

Wear safety gloves when changing the saw blade. Risk of injury!

- Swing up the machine head (4).
- Undo the screw (e) on the guide bar (37), so that it can move freely and be pivoted downwards.
- Press the release button (3). Swing up the saw blade guard (5) to the point where the recess in the saw blade guard (5) is above the flange bolt (29/30/31).
- Press the saw machine head (4) with one hand. With the other hand insert the allen key (d) in the flange bolt (29/30/31).
- Hold the Allen key (d) and slowly close the saw blade guard until it touches the Allen key.
- Firmly press the saw shaft lock (31) and slowly rotate the saw shaft lock (31) in clockwise direction. The saw shaft lock (31) engages after no more than one rotation.
- Now, using a little more force, slacken the saw shaft lock (31) in the clockwise direction.
- Turn the saw shaft lock (31) right out and remove the inner flange (32).
- Take the blade (6) off the inner flange (32) and pull out downwards.
- Carefully clean the flange screw (31), outer flange (30) and inner flange (32).



Maintenance and electrical connection

Maintenance



WARNING!

Prior to any adjustment, maintenance or service work disconnect the mains power plug!

General maintenance measures

- Wipe chips and dust off the machine from time to time using a cloth. In order to extend the service life of the tool, oil the rotary parts once monthly. Do not oil the motor.
- When cleaning the plastic do not use corrosive products.

Brush inspection

Check the carbon brushes after the first 50 operating hours with a new machine, or when new brushes have been fitted. After carrying out the first check, repeat the check every 10 operating hours.

If the carbon is worn to a length of 6 mm, or if the spring or contact wire are burned or damaged, it is necessary to replace both brushes. If the brushes are found to be usable following removal, it is possible to reinstall them.

Service information

Please note that the following parts of this product are subject to normal or natural wear and that the following parts are therefore also required for use as consumables.

Wear parts*: Carbon brush, saw blade, table inserts, dust bags, batteries,

* Not necessarily included in the scope of delivery!

Electrical connection

The electrical motor installed is connected and ready for operation. The connection complies with the applicable VDE and DIN provisions.

The customer's mains connection as well as the extension cable used must also comply with these regulations.

- The product meets the requirements of 62841-3-9 and is subject to special connection conditions. This means that use of the product at any freely selectable connection point is not allowed.
- Given unfavorable conditions in the power supply the product can cause the voltage to fluctuate temporarily.
- The product is exclusively intended for use at connection points that have a continuous current-carrying capacity of at least 100 A per phase.
- As the user, you are required to ensure, in consultation with your electric power company if necessary, that the connection point at which you wish to operate the product meets the specified requirements. Kinks where the connection cable has been improperly fastened or routed.

Important information

In the event of an overloading the motor will switch itself off. After a cool-down period (time varies) the motor can be switched back on again.

Damaged electrical connection cable

The insulation on electrical connection cables is often damaged.

This may have the following causes:

- Passage points, where connection cables are passed through windows or doors.
- Kinks where the connection cable has been improperly fastened or routed.
- Places where the connection cables have been cut due to being driven over.
- Insulation damage due to being ripped out of the wall outlet.
- Cracks due to the insulation ageing.

Such damaged electrical connection cables must not be used and are life-threatening due to the insulation damage.

Check the electrical connection cables for damage regularly. Make sure that the connection cable does not hang on the power network during the inspection.

Electrical connection cables must comply with the applicable VDE and UK provisions. Only use connection cables with the marking „H 07 RN“.

The printing of the type designation on the connection cable is mandatory.

AC motor

- The mains voltage must be 220-240 V~
- Extension cables up to 25 m long must have a cross-section of 1.5 mm².

Connections and repairs of electrical equipment may only be carried out by an electrician.

Please provide the following information in the event of any enquiries:

- Type of current for the motor
- Machine data - type plate
- Machine data - type plate

Transport

- Tighten the set screw (26) in order to lock the turntable (14)
- Activate the release button (3), press the machine head (4) downwards and secure with the fastening bolt (23). The saw is now locked in its bottom position.
- Fix the saw's drag function with the locking screw for drag guide (20) in rear position.
- Carry the equipment by the fixed saw table (15).
- When reassembling the equipment proceed as described under "Before starting the equipment"

Storage

Store the machine and its accessories in a dark, dry and frost-free place, inaccessible to children. The ideal storage temperature is between 5 and 30°C.

Store the power tool in its original packaging. Cover the power tool to protect it from dust and humidity.

Keep the operating manual with the power tool.

DISPOSAL AND RECYCLING

Disposing of transport packaging

The packaging protects the machine from damage during transport. The packaging material is usually chosen for factors of environmental friendliness and disposal. It can therefore be recycled. Returning the packaging to the material life cycle saves raw material and reduces waste.

Packaging parts (e.g. plastic sheets, Styropor®) can be dangerous for children. Risk of choking! Store packaging parts beyond the reach of children and dispose of them as soon as possible

Old devices must not be disposed of with household waste!



This symbol indicates that this product must not be disposed of together with domestic waste in compliance with the Directive (2012/19/EU) pertaining to waste electrical and electronic equipment (WEEE). This product must be disposed of at a designated collection point. This can occur, for example, by handing it in at an authorised collecting point for the recycling of waste electrical and electronic equipment. Improper handling of waste equipment may have negative consequences for the environment and human health due to potentially hazardous substances that are often contained in electrical and electronic equipment. By properly disposing of this product, you are also contributing to the effective use of natural resources. You can obtain information on collection points for waste equipment from your municipal administration, public waste disposal authority, an authorised body for the disposal of waste electrical and electronic equipment or your waste disposal company.

JCB Tools Warranty Terms and Conditions

JCB Power Tools are guaranteed against manufacturing defects for 2 years from date of purchase by simply registering your product on-line within 30 days. Proof of purchase required. This does not affect your statutory rights.

To register your JCB Power Tool, please visit: jcb-tools.com

Online registration is required to receive a warranty certificate to activate your standard 2 year warranty. Registration is only available online via www.jcb-tools.com. You will need your original sales receipt, the model number and the serial number (if applicable) of your product. Kits comprising of two or more tools are excluded from single registration and must be registered individually for full warranty cover.

Upon successful registration, a warranty certificate will be available to download, print or save as a PDF document. The relevant warranty certificate together with the original sales receipt will be required in the event of any claim within the warranty period.

Should you choose not to register your product within 30 days of purchase, your statutory consumer rights will not be affected. You will need the original sales receipt as proof of purchase in the event of a warranty claim.

Warranty cover commences from the date of purchase on the retail sales receipt and is valid only for JCB Tools products purchased within the UK bearing the CE mark and a visible serial number.

In the unlikely event your JCB Power Tool is subject to a manufacturing fault within the warranty period, JCB Tools may repair the product by replacing defective parts free of charge at our discretion. In the event parts are irreplaceable JCB Tools may replace your product free of charge. The original product will remain the property of JCB Tools in this situation.

The above repair or replacement of products will be undertaken providing that:

- The product has been subject to fair wear and tear only.
- The product has not been subject to accidental or cosmetic damage.
- The product has not been misused and has been used only in accordance with the instruction manual provided.
- The product has not been subject to overload or insufficient servicing and maintenance.
- The product has not been subject to any abnormal environmental conditions or inappropriate operating conditions.
- Repairs have not been attempted by an unauthorised person and no modifications have been made to the product.
- Repairs have not been undertaken using non-genuine spare parts.



JCB Power Tools used for Hire Fleets or as part of B2B and Service Contracts are not covered by these terms and conditions.

JCB Tools standard 2 Year warranty excludes the following (where relevant);

- Components normally subject to wear such as carbon brushes.
- Batteries, Chucks and Chargers.
- Accessories and consumable items.
- Cases and tool storage products.

If your product develops a fault within 30 days of purchase, return it to the retailer where it was purchased together with your sales receipt. If a product develops a fault after 30 days a warranty claim must be submitted.

If you have a warranty claim please take your product, original sales receipt and if applicable, a copy of your extended warranty certificate to your local JCB Tools dealer.

If you wish to send your product to us directly, please call us on 03308380257 to arrange warranty claim or repair. Delivery and repair charges may apply at our discretion should the warranty claim be invalid for any of the reasons illustrated above. In the event charges are not accepted the product will be retained by JCB Tools and remain the property of JCB Tools.

The information on both your sales receipt and your extended warranty certificate must match.

JCB TOOLS WILL NOT BE LIABLE FOR ANY INJURIES OR CONSEQUENTIAL DAMAGES RESULTING FROM USE OF THIS PRODUCT.

EC DECLARATION OF CONFORMITY

Original Declaration of Conformity

We,

JCB Tools

Declare that the product:

Description: Sliding cross cut mitre saw

Type: JCB-MS-210SB

Function: Split cuts in wood and plastic.

Complies with the following Directives;

EC Machinery Directive **2006/42/EC**

EC Electromagnetic Compatibility Directive **2014/30/EU**

RoHS Directive **2011/65/EU***

Standards conform to

EN62841-1:2015+AC:15

EN62841-3-9:2015

EN55014-1:2017

EN55014-2:2015

EN61000-3-2:2014

EN61000-3-3:2013

This declaration of conformity is issued under the sole responsibility of the manufacturer.

***The object of the declaration described above fulfils the regulations of the directive 2011/65/EU of the European Parliament and Council from 8th June 2011, on the restriction of the use of certain hazardous substances in electrical and electronic equipment.**

The person authorized to compile the technical file:

Date: 04/01/2019

Signature:



Name/ title: Mya Yee Lwin / Quality Assurance Manager

Address: JCB Tools, 55 Romsey Industrial Estate, Romsey,
SO51 0HR, UK. (REG: 11062222)

Company Registration Number: 1062222